

Extending the life
of the fields

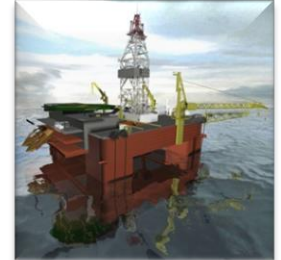

Better ways of working with Asset Integrity data

Location: Digital Energy Journal, Stavanger

Date: Wed 30th October

Asset Integrity Management/ MMO

Health, safety and environment: a top priority

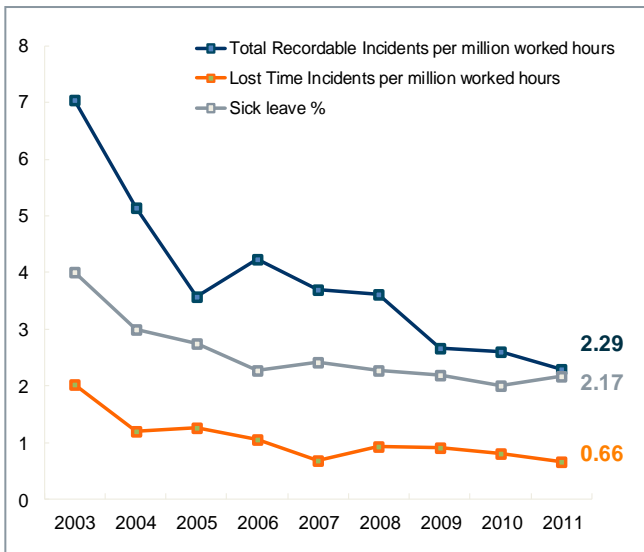

Our vision is to be the preferred partner for solutions in the oil and gas industry through living our values.



This is Aker Solutions



Employees: **21 500**
Contract staff: **6 500**
Revenues: **44.9 bn**
EBITDA: **4.7 bn**
Market Cap: **32.4 bn**

Revenues and profits are in NOK and for 2012.
Market capitalisation as of February 2013.

- Provides oilfield products, systems and services for customers in the oil and gas industry world-wide
- Built on more than 170 years of industrial tradition
- Employs approximately 28 000 people in more than 34 countries

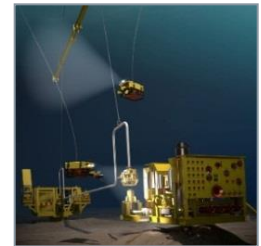

Business areas

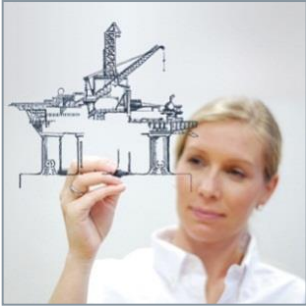

Engineering



Drilling technologies

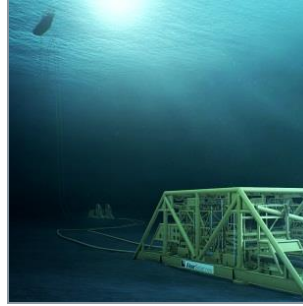

Subsea



Umbilicals



Process systems



Mooring and loading systems



Maintenance, modifications and operations



Oilfield services and marine assets



Well intervention services

Where we are – a global footprint

Countries: **34**

Locations: **~ 80**

- engineering hubs
- service bases
- manufacturing plants
- sales offices
- project management

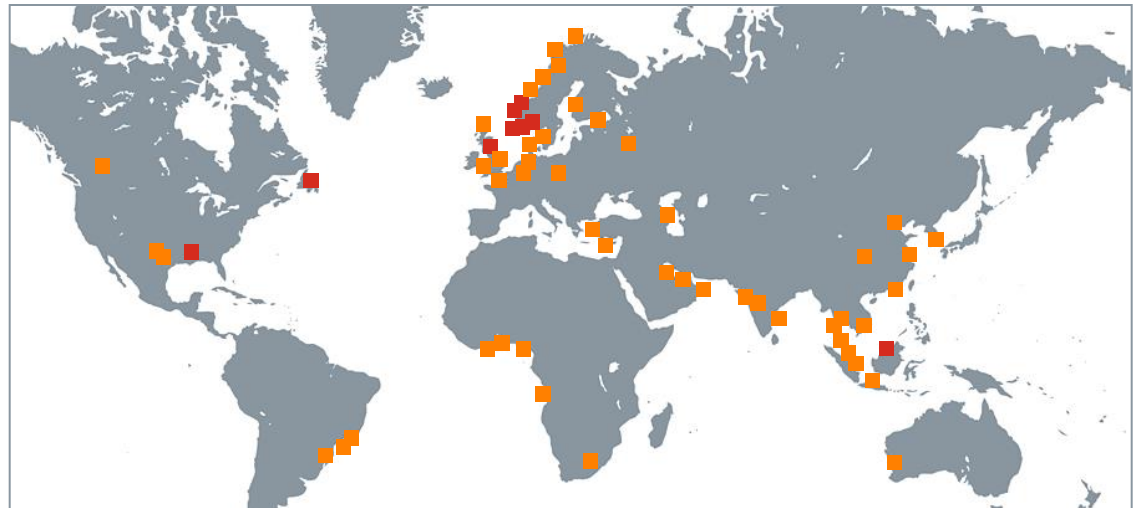

Angola

Luanda

Australia

Perth

Azerbaijan

Baku

Brazil

Curitiba
Rio das Ostras
Rio de Janeiro

Brunei

Canada

Calgary
St. John's

China

Beijing
Shanghai
Shenzhen
Yichang

Cyprus

Limassol

Denmark

Copenhagen
Esbjerg

Equ. Guinea

Malabo

Finland

Helsinki
Ulvila

France

Paris

Germany

Bad Fallingbostal
Erkelenz

Ghana

Takoradi

India

Kakinada
Mumbai
Pune

Indonesia

Batam
Jakarta

Ivory Coast

Abidjan

Malaysia

Kuala Lumpur
Labuan
Pekan
Port Klang

Nigeria

Lagos
Port Harcourt

Norway

Asker
Arendal
Bergen
Egersund

Norway [cont.]

Fornebu
Hammerfest
Horten
Kristiansand S
Kristiansund N
Kollsnes/Sture
Lyngdal
Midsund
Moss
Mongstad
Narvik
Oslo
Porsgrunn
Sandnessjøen
Stavanger
Stokke
Stord
Tranby
Tromsø

Norway [cont.]

Trondheim
Ågotnes
Ålesund

Oman

Muscat

Russia

Moscow
St Petersburg

Saudi Arabia

Al-Khobar

Singapore

Singapore

South Africa

Germiston

South Korea

Gyungnam
Pusan

Sweden

Gothenburg

Thailand

Bangkok
Sattahip
Songkhla

UAE

Abu Dhabi
Dubai

UK

Aberdeen
Great Yarmouth
Hastings
London
Maidenhead
Stockton-on-Tees
Whitstable

USA

Houston
Katy
Mobile

Vietnam

Vung Tau

Name in red = Dedicated AIM offices

Index

- **Introduction of MMO Asset Integrity Management (AIM)**

- Asset Integrity management throughout an asset's lifetime and services applicable for Subsea Integrity Management

- Systems and Technology

Asset Integrity Management

Global footprint and opportunities for more than 350 engineers and inspection specialists

- Norway
 - Engineering Services
 - Oslo
 - Stavanger
 - Bergen
 - Trondheim
 - Field Services
 - Bergen
 - Mongstad
 - Ågotnes
 - Kristiansund
 - In-Service Inspection
 - Stavanger
 - Bergen
 - Kollsnes
 - Sture
 - Mongstad
 - Stjørdal
- UK
 - Engineering Services
 - Aberdeen
 - Glasgow
- North America
 - Houston
 - St. Johns (Canada)

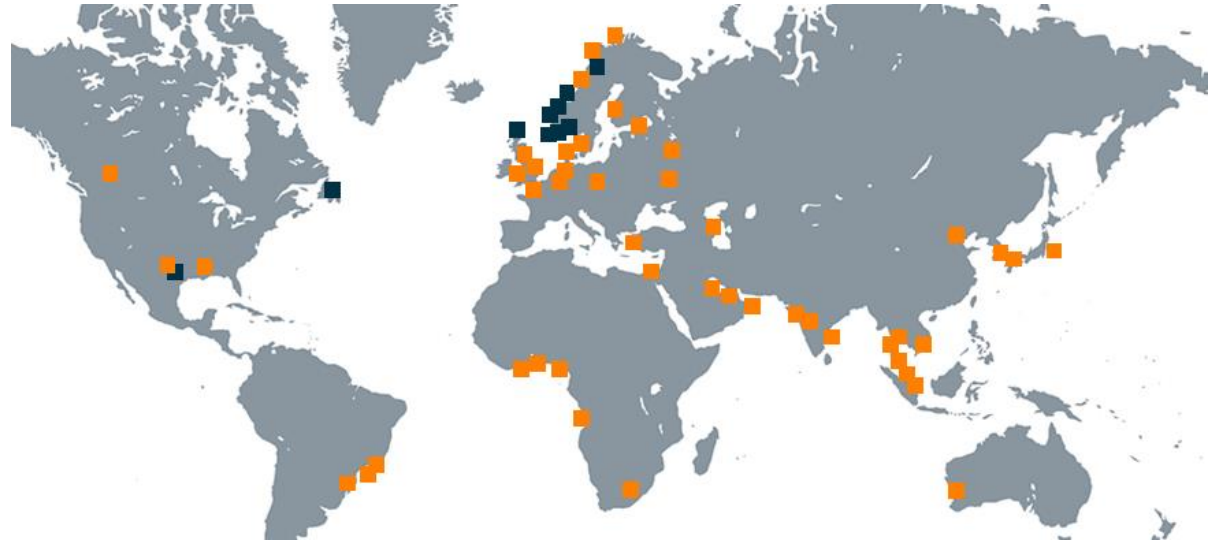

- Aker Solutions Office
- Aker Solutions, AIM Office

Countries: **34**
Locations: **~ 80**
- engineering hubs
- service bases
- manufacturing plants
- sales offices
- project management



Asset Integrity Management (AIM) a strategic business stream in Maintenance Modification and Operation (MMO)

Major modifications and E&C frame agreements

Front-end

Asset
integrity
mgmt.

Fabrication

Hock-up

Decom



Aker Solutions Asset Integrity Management (AIM)

Aker Solutions is a leading AIM player in NCS, differentiated by providing services across the entire life cycle

- Aker Solutions is one of the leading suppliers of AIM services in NCS and the largest supplier of inspection execution and maintenance planning for upstream O&G in Norway
- Have the capability to deliver complete range of services required to ensure the technical integrity of an asset – from in-service inspection and condition monitoring to analysis of degradations and development of complete maintenance and inspection programs



Systems & Methods



Integrity Engineers

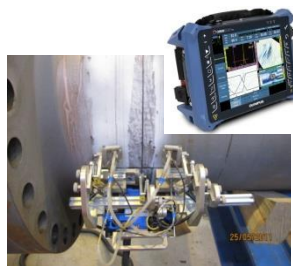

Tools & Technology



Field Services

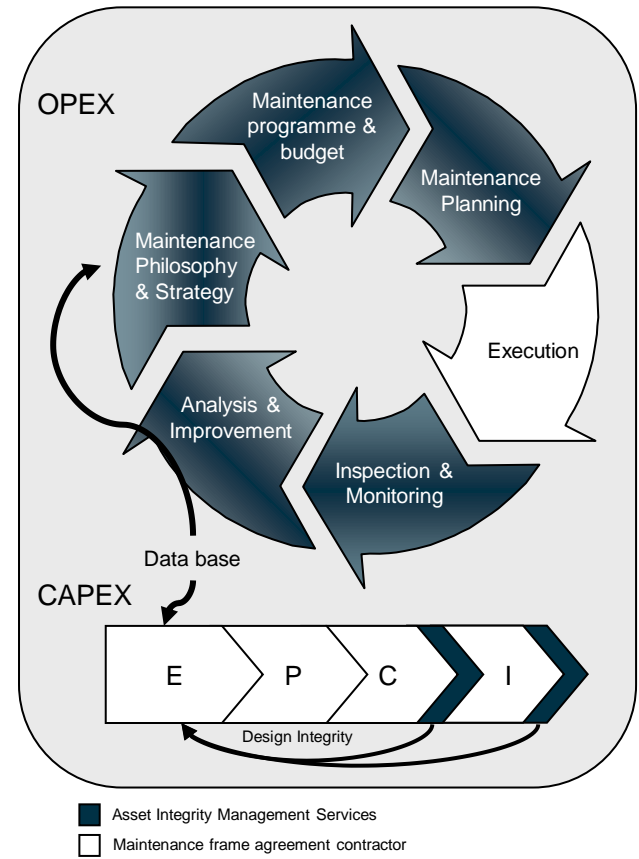

Aker Solutions Asset Integrity Management delivers a unique combination of engineering and field services covering the complete asset lifecycle.

Engineering Services



Maintenance & Inspection Engineering



Structural Integrity Management

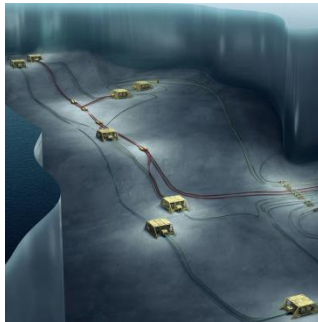

Subsea Integrity Management



Data Management, Systems & Tools

Field Services



In-Service Inspection & Corrosion Management

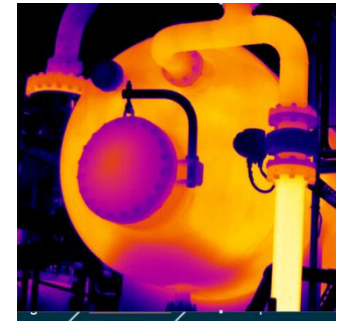

Advanced Inspection & Monitoring Technology



Inspection (NDT) and Quality Control



Rope Access Services



Asset Integrity Management has a role in all phases of an assets lifecycle

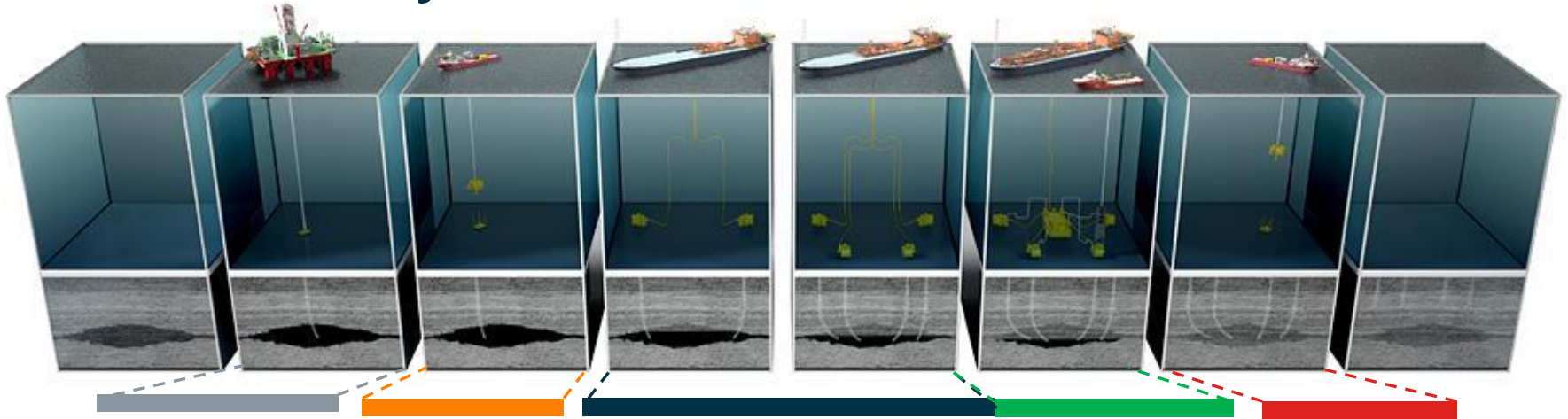

Exploration

- Integrity Management of mobile drilling rigs
- NDT Inspection

Development

- Concept, FEEDs, Feasibility
- Tech.Integrity analysis/studies
- Maint. engineering.
- IO, CM/CBM Strategy
- Non-Intrusive tech.strategy
- Riser and Umbilical analysis
- Baseline Inspection

Production

- Field Services
- In-Service Inspection
- Maintenance and Inspection plan and preparation
- Advanced Inspection and Monitoring Technology

Life Extensions

- Integrity assessment and analysis quantifying remaining life of plant, systems and equipment
- Structural Inspection and Maintenance Program analyses, SIMP™

Decom.

- Safe decomm and removal
- Structural Analysis and Inspection

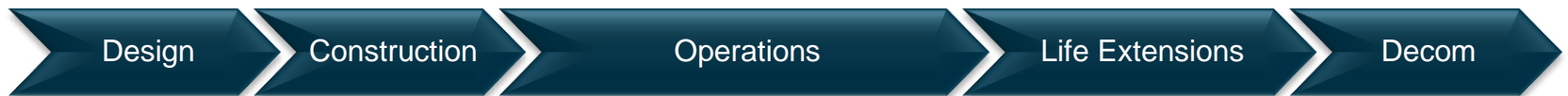

Index

- Introduction of MMO Asset Integrity Management (AIM)
- Asset Integrity management throughout an asset's lifetime and services applicable for Subsea Integrity Management
- Systems and Technology

Asset Integrity Management starts at early design...

The foundation for an optimal Asset Integrity Management Program is made during the design phase:

Design & Strategy Analysis

- Integrity Management Philosophy & Strategies
- Maintenance Philosophy & Strategies
- IO and CM/CBM Strategy
- Risk Assessments
- Design Review and Verification
- Material evaluation and selection
- Reliability, Availability and Maintainability analysis (RAM)
- SIL assessment
- Failure mode, effects, and criticality analysis (FMECA)
- Production availability analysis
- Operations workload analysis
- Regularity analysis
- LCC/LCI analysis
- Manning and OPEX analysis
- Work Processes
- Process Safety and Hazards Analysis (PHA/HAZOP)

Maintenance & Inspection Programs

- Maintenance & inspection management systems
- Criticality Analysis
- Reliability Centered Maintenance (RCM)
- Risk Based Inspection analysis (RBI)
- Structural Inspection Program (SIMP)
- Condition-based maintenance planning
- Integrated Operations planning

Increased focus on Integrated Operations (IO) and Condition Monitoring Strategies at an early stage to ensure equipment and systems is designed for real time condition monitoring

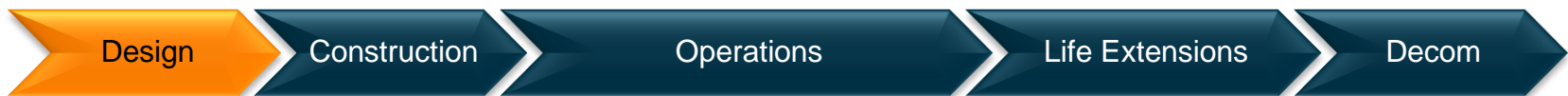

...continues throughout fabrication and construction...

■ Ensure quality of:

- Materials
- Welds
- Measurements
- Drawings
- Documentation
- etc...

■ Save baseline technical condition data in integrity databases to improve future condition analysis and trending

MMO AIM fab & construction project examples:

- Development and qualification of welding and inspection procedures
- 3rd party verification
- Inspection (NDT) and quality control during fabrication and construction
- Advanced inspection technology to improve quality and efficiency of inspection (focus on classing)



Inspection of new riser using Phased Array and Time of Flight Ultrasonic

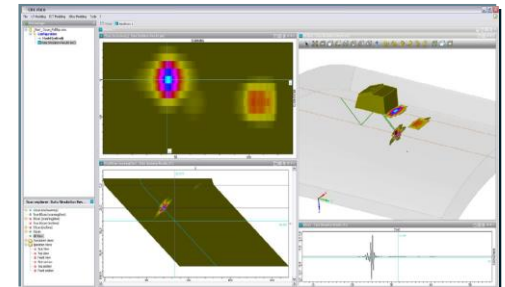

Development of inspection procedures using advanced simulation

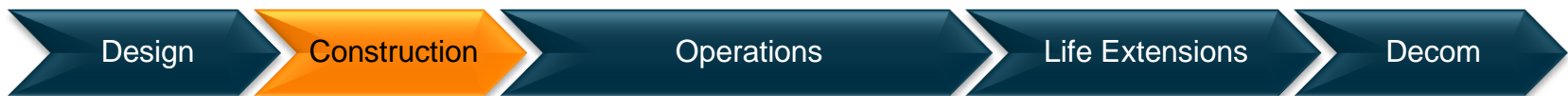

...lives on during operation to ensure safe operation, optimized availability and reduced cost

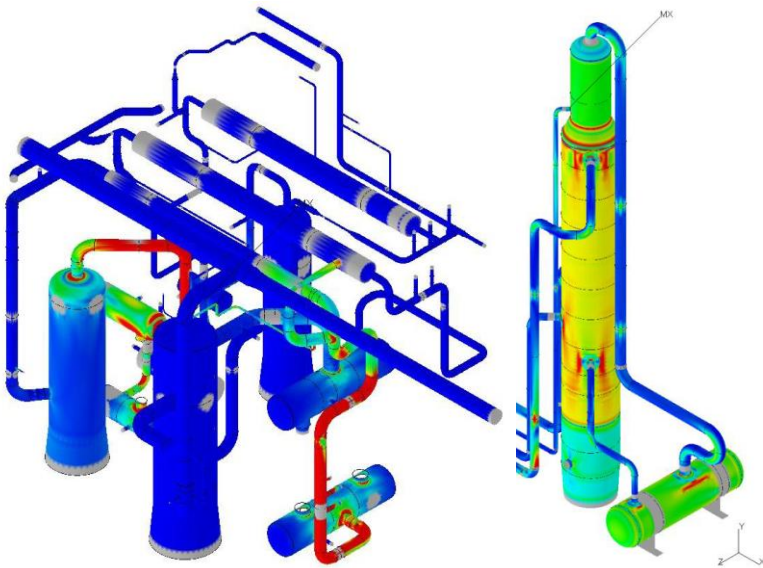
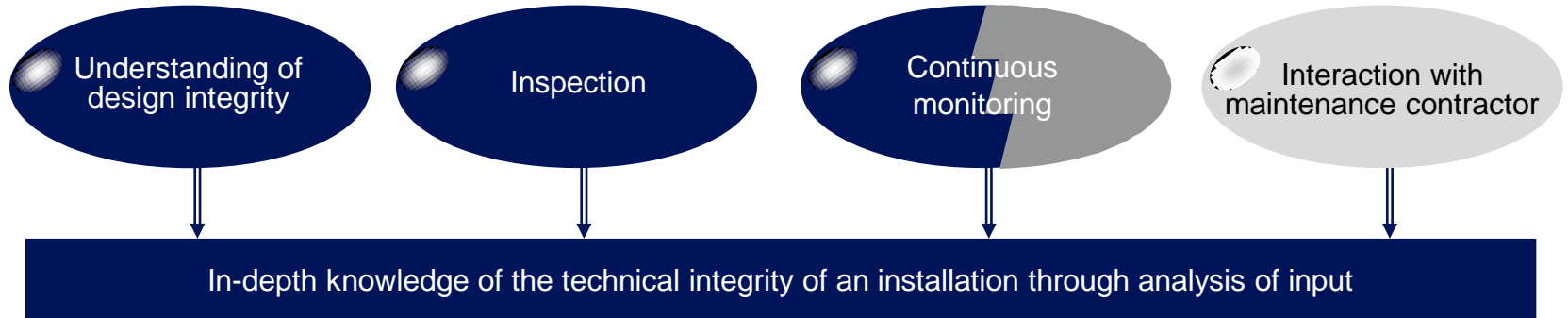

MMO AIM in-service/operation project examples:

- Inspection (NDT) of subsea equipment during overhaul/repair at Ågotnes
- Re-classing of risers using Advanced inspection technology
- Development and optimization of maintenance and inspection programs
- Integrity assessment and analysis to quantify remaining life and fitness for services (FFS) to optimize operation



Advanced Inspection Technology

“Find all defects and degradations before they become critical”

In the lead developing solutions and new applications

Engineering competence and hands on experience

Advanced Electromagnetic Inspection

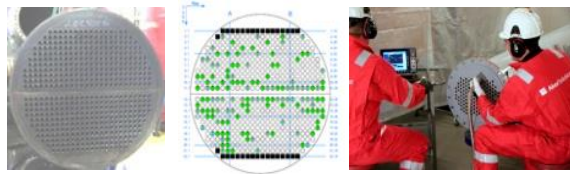

Vibration & Stress Measurement

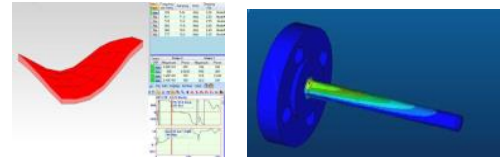

Advanced Ultrasonic Inspection

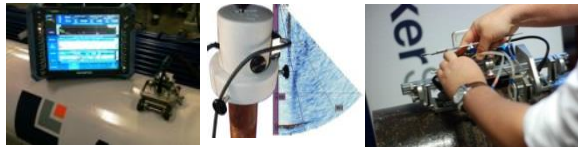

Digital Radiography



Advanced Thermographic Inspection

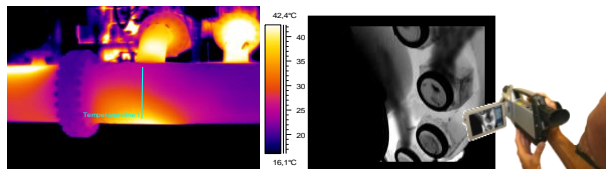

Video



Design

Construction

Operations

Life Extensions

Decom

New opportunities with “Digital Inspection Methods”

- Increased coverage, speed, POD and sizing = “more reliable”
- Real documentation and possible to “re-analyse”
- Remote Analysis - send data from offshore to onshore or any location
- Central storage of data – “no paper in a drawer” — better access
- Compare new and old results (trending) and compare results from different equipment and methods

Improved Life Time calculations

Better input to RBI/RCM models

Adjust and optimize intervals/plans

Improved Integrity Management and increased confidence

Design

Construction

Operations

Life Extensions

Decom

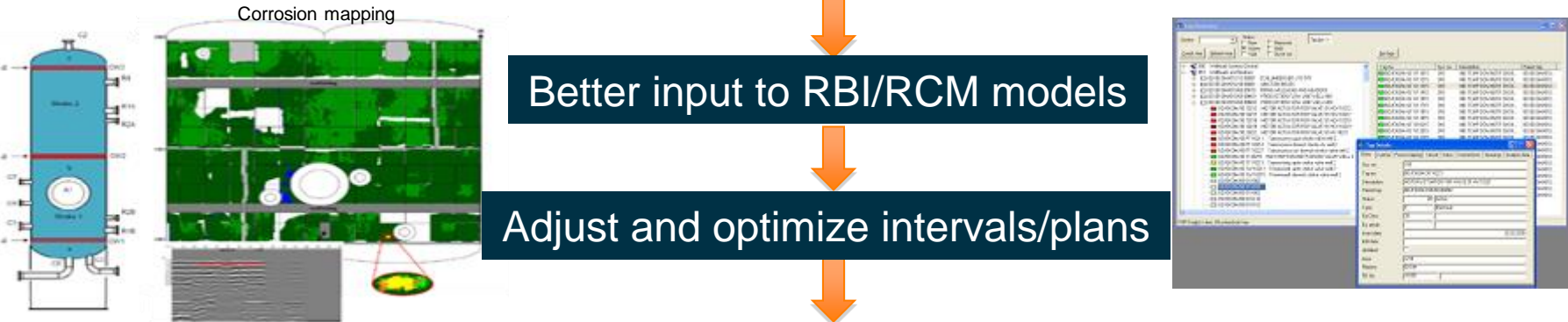

Advanced Inspection Technology

Subsea and riser inspection

- NDT Level III service for Subsea
- Various subsea component recertification
- HPDR recertification
- Merlin risers recertification
- Casing risers recertification
- Clip risers recertification
- WOS risers 3.party evaluation
- WOS risers recertification
- WOS risers – Phased Array and ToFD weld inspection

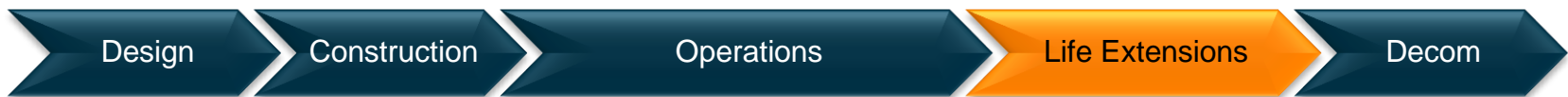
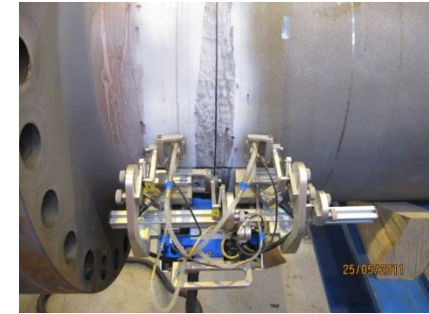

Life extension (Examples)

Inspection and re-certification of Riser at Aker Ågotnes

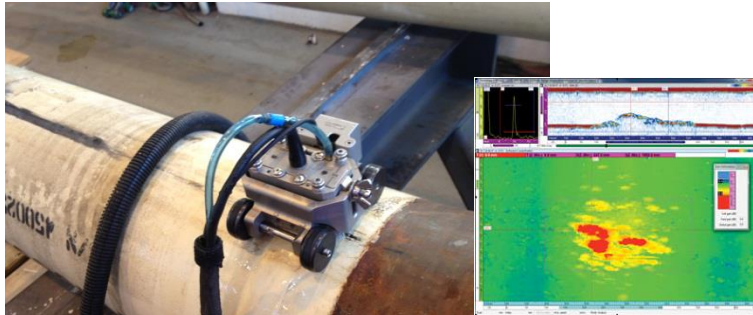

Phased Array and ToFD inspection



Weld-rover

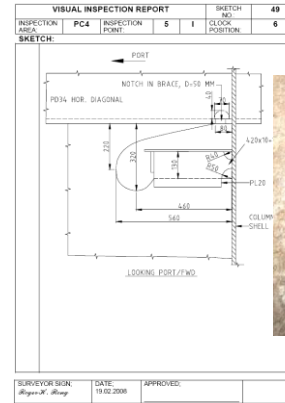

- Production platforms (lifetime extension):
 - Statoil, Njord A, 2011
 - Petrofac, Northern Producer, 2008
 - Statoil, Veslefrikk A, 1999

- Drilling platforms (SIMP™ implemented):
 - Stena Drilling, Stena Spey, 2013
 - Songa Offshore, Songa Dee, 2011
 - Dolphin Drilling, Borgny Dolphin, 2010
 - Dolphin Drilling, Borgholm Dolphin, 2008
 - Dolphin Drilling, Bredford Dolphin, 2007
 - Odfjell Drilling, Deepsea Delta, 2006
 - Odfjell Drilling, Deepsea Bergen, 2005
 - Dolphin Drilling, Port Reval, 2005
 - Dolphin Drilling, Byford Dolphin, 2005
 - Dolphin Drilling, Borgsten Dolphin, 2005
 - Odfjell Drilling, Deepsea Trym, 2004

Design

Construction

Operations

Life Extensions

Decom

SIMP™ method

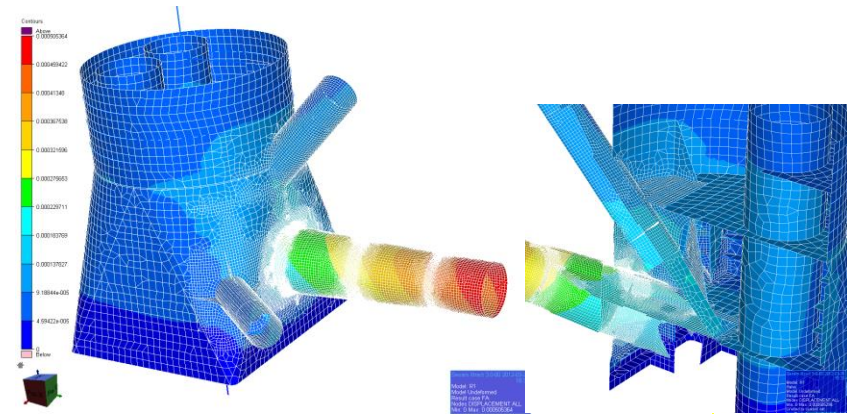

Local FE models for calculation of SCF in fatigue areas FE model run separately
 Establishing relation between beam model and local FE model
 Hot spot method applied with mesh t x t

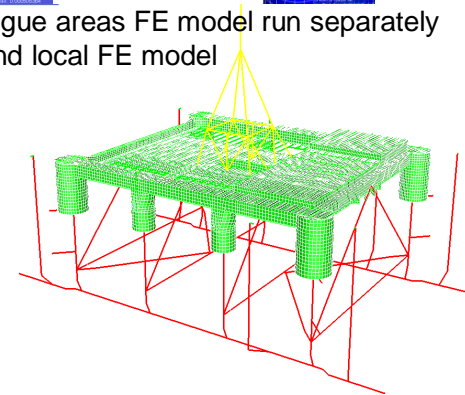
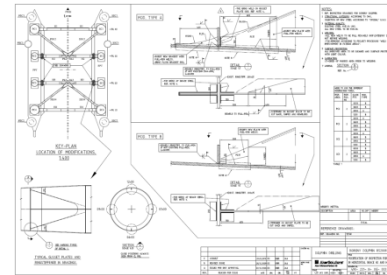

- As-Is verification
 - Verify modification scope
 - Modification ok?
 - Painting ok?
 - Toe grinding ok?
- Establish inspection scope for the next RS
 - Based on fatigue life
 - Inspection, modification and crack history
 - 5 years intervals
- Updating inspection history and inspection program continuously
- Benefits implementing SIMP™
 - More cost effective inspection
 - Reduced risk of through thickness cracks
 - Higher reliability
 - In-shore inspection every 5 year not every 2.5 year
 - Higher operability

Result:

- ✓ Modification scope for the next Renewal Survey (RS) to reach a fatigue life of 20 years.
- ✓ Modified IIP
- ✓ Inspection scope for the next RS
- ✓ Class approved drawings



...finally, it ends with decommissioning of the asset

- Focus on HSE!
- Inspection of structures and equipment to ensure safe disassembly and lifting operation
- Ensure hazardous materials are detected and handled correctly

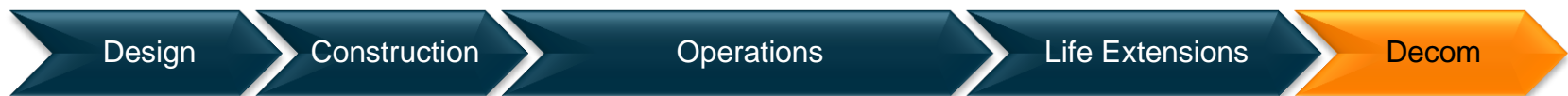

Index

- Introduction of MMO Asset Integrity Management (AIM)
- Asset Integrity management throughout an asset's lifetime and services applicable for Subsea Integrity Management
- **Systems and Technology**

Data Management, Systems and Tools

To meet the customer requirements...

Cost efficient execution

Our internal systems enables low-cost, high quality execution based on our proprietary experience database

Simple, low-risk integration

Our offering is easy to implement and integrate with client systems, and require limited use of IT consultancy, e.g. SAP

Comprehensive CMMS integration

We are able to serve high-end clients with comprehensive systems partnering with high-end software providers

...our current systems portfolio...

Coabis™ Integrity Management
Integri-Tech FFS

Pyramid – Maintenance & Inspection Engineering and Analysis

SIMP™
Structural Integrity Maintenance Program

...integrates through myAIM

Evaluation & optimization analysis

Condition monitoring and inspection execution

Maintenance & inspection programs and plans

Condition based maintenance support

Design & strategy analysis

Integration with client work processes and CMMS
(Computerized Maintenance Management System)

State of the art integrated modular portfolio of integrity management

Coabis and Integri-Tech

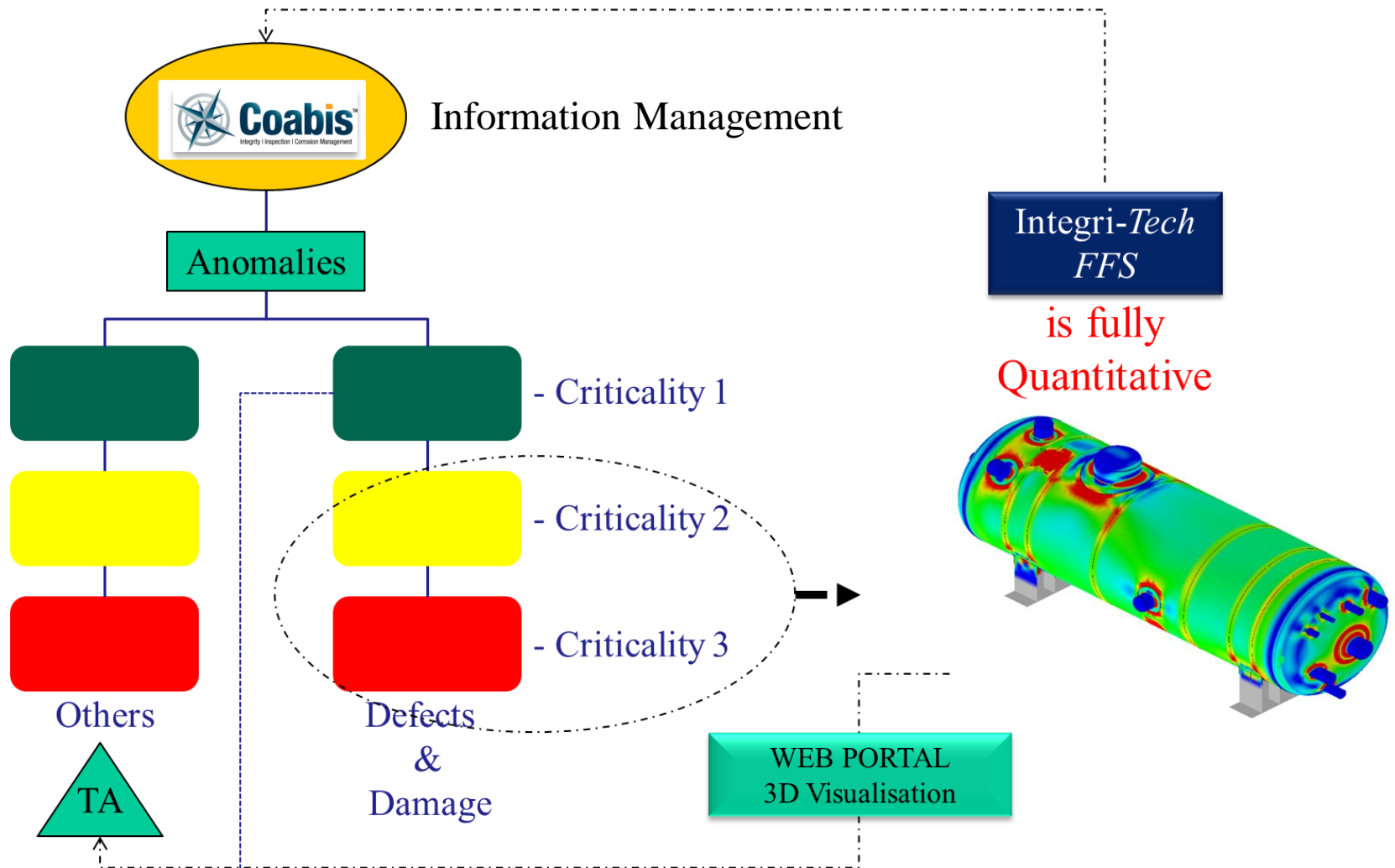

Advanced Inspection Technology

Center of Competence



Center of competence for development of procedures and techniques.

Storage of all digital inspection data and reports.

Level III evaluation of results.

3. party evaluation.



Delivering all aspects of Asset Integrity Management

- MMO AIM scope the integrity engineering projects based on the Customer needs and the development phase, operational phase and the condition of the assets

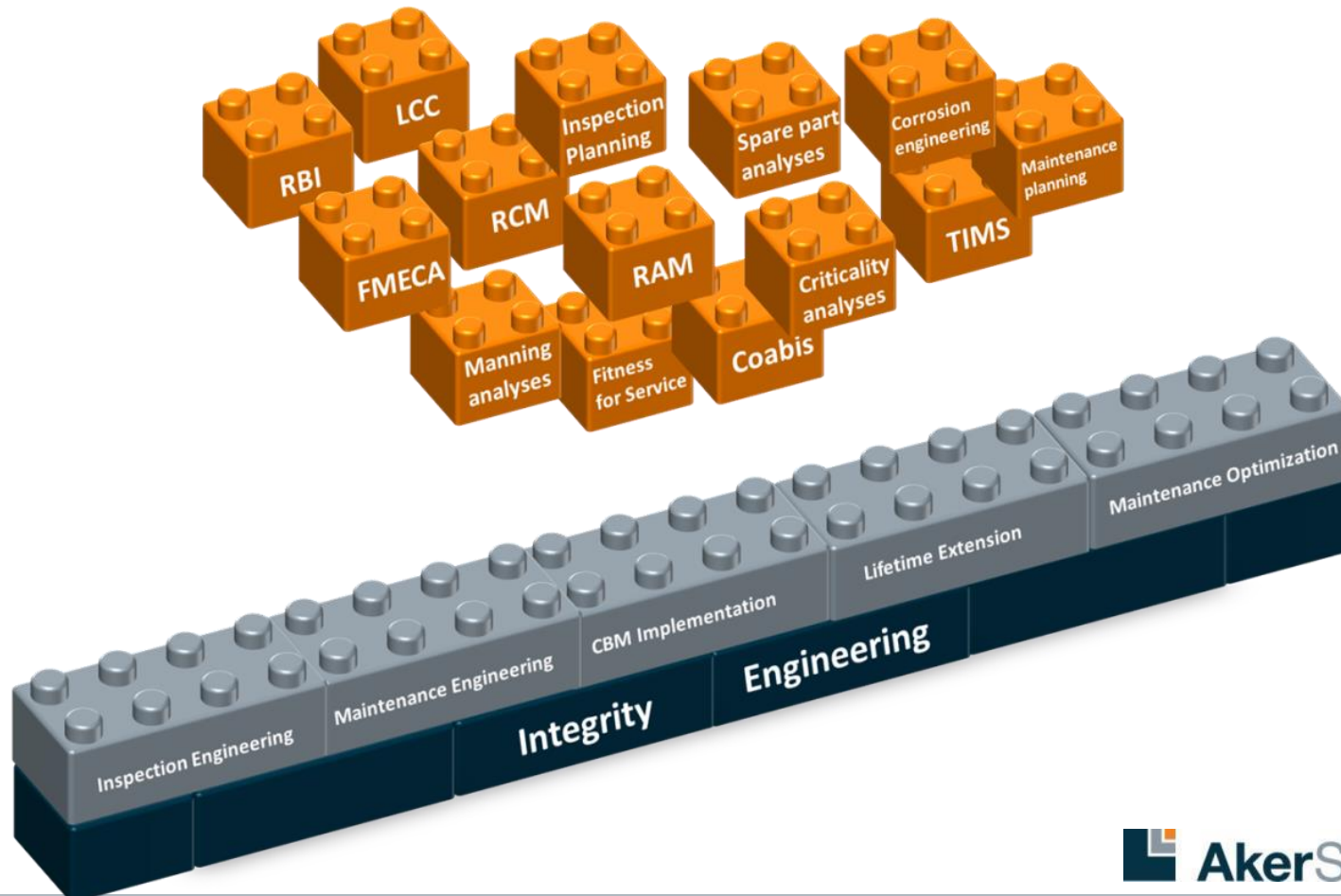

Technical Integrity Analysis and Studies

Risk Based Inspection

- Secure optimum availability at acceptable risk.
- Prioritize inspection efforts on the items driving the risk.

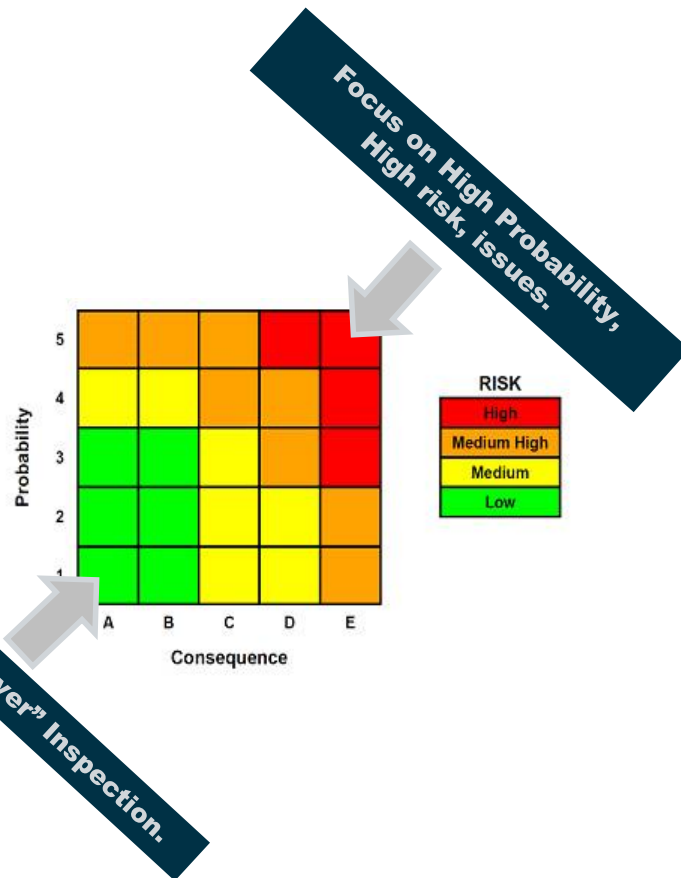

Non-Intrusive Inspection (NII)

- Where the RBI identifies internal degradation mechanisms which can be followed up through periodic inspection, it is recommended to evaluate if the inspection can be performed non-intrusively.

Technical Integrity Management Services (TIMS)

- TIMS is a multidisciplinary service which brings together a unique package of expertise, tools and systems to help the Client achieve optimum asset performance.



TIMS – Lifecycle Technology Condition Based Maintenance



An Aker Solutions initiative within Integrity Management services.



Aker Solutions offer Integrated Operation

Access to more and better technical condition data improves Integrated Operations and Asset Integrity Management



Questions?



To be the preferred global asset integrity management partner to the oil & gas industry providing services across the entire lifecycle of an asset

Copyright and disclaimer

Copyright

Copyright of all published material including photographs, drawings and images in this document remains vested in Aker Solutions and third party contributors as appropriate. Accordingly, neither the whole nor any part of this document shall be reproduced in any form nor used in any manner without express prior permission and applicable acknowledgements. No trademark, copyright or other notice shall be altered or removed from any reproduction.

Disclaimer

This Presentation includes and is based, inter alia, on forward-looking information and statements that are subject to risks and uncertainties that could cause actual results to differ. These statements and this Presentation are based on current expectations, estimates and projections about global economic conditions, the economic conditions of the regions and industries that are major markets for Aker Solutions ASA and Aker Solutions ASA's (including subsidiaries and affiliates) lines of business. These expectations, estimates and projections are generally identifiable by statements containing words such as "expects", "believes", "estimates" or similar expressions. Important factors that could cause actual results to differ materially from those expectations include, among others, economic and market conditions in the geographic areas and industries that are or will be major markets for Aker Solutions' businesses, oil prices, market acceptance of new products and services, changes in governmental regulations, interest rates, fluctuations in currency exchange rates and such other factors as may be discussed from time to time in the Presentation. Although Aker Solutions ASA believes that its expectations and the Presentation are based upon reasonable assumptions, it can give no assurance that those expectations will be achieved or that the actual results will be as set out in the Presentation. Aker Solutions ASA is making no representation or warranty, expressed or implied, as to the accuracy, reliability or completeness of the Presentation, and neither Aker Solutions ASA nor any of its directors, officers or employees will have any liability to you or any other persons resulting from your use.

Aker Solutions consists of many legally independent entities, constituting their own separate identities. Aker Solutions is used as the common brand or trade mark for most of these entities. In this presentation we may sometimes use "Aker Solutions", "we" or "us" when we refer to Aker Solutions companies in general or where no useful purpose is served by identifying any particular Aker Solutions company.